

NKM-G 100-250 - 4 POLES - STANDARDISED MONOBLOC PUMPS

Pumped liquid temperature range: from -10 °C to +140 °C - Maximum ambient temperature: +40°C

≈ 1450 1/min

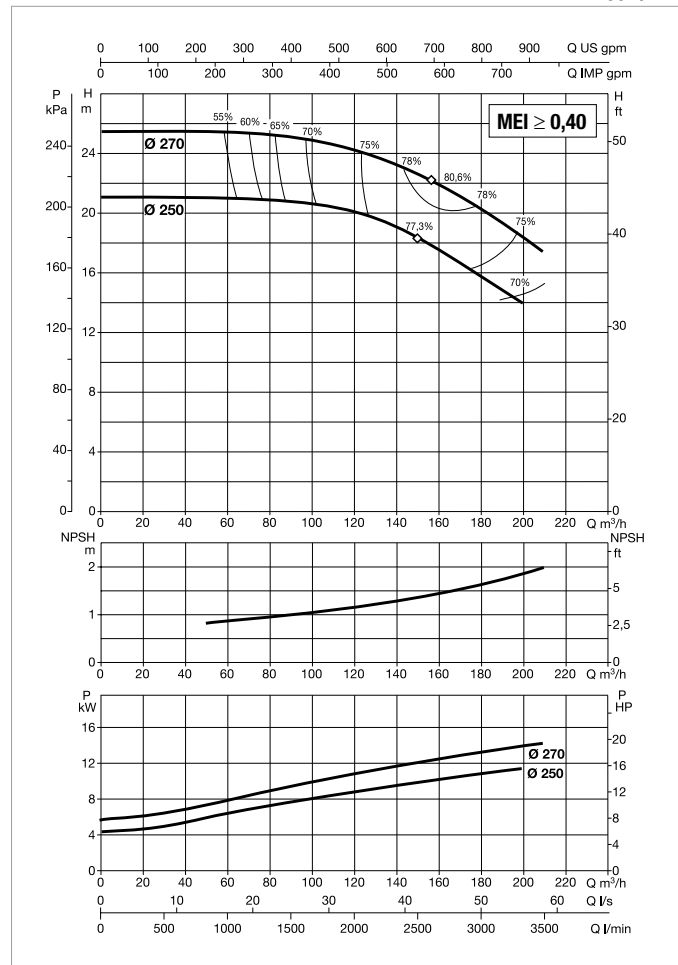
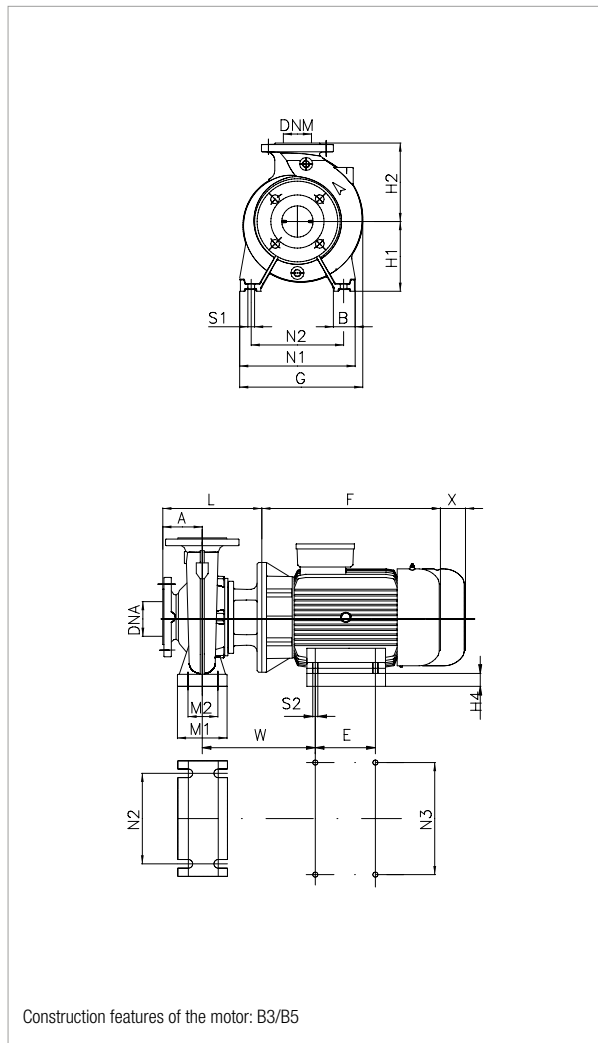

For MEI index refer to the hydraulic efficiency section.

The performance curves are based on kinematic viscosity values = 1 mm²/s and density equal to 1000 kg/m³. Curve tolerance according to ISO 9906.

MODEL	ELECTRICAL DATA						
	MOTOR SIZE	POWER INPUT 50 Hz	P2 NOMINAL		In A		MOTOR TYPE
			kW	HP	230 V	400 V	
NKM-G 100-250/250/11/4	MEC 160 M	3 x 400 V ~	11	15	-	22,4	IE3
NKM-G 100-250/270/15/4	MEC 160 L	3 x 400 V ~	15	20	-	30,5	IE3

MODEL	A	B	E	F	G	H1	H2	L	M1	M2	N1	N2	N3	S1	S2	W	X	H3	H4	Ø (mm) Mech. seal	DNA	DNM	PACKING DIMENSIONS			VOLUME (m³)	WEIGHT Kg
																							L/A	L/B	H		
NKM-G 100-250/250/11/4	140	80	210	498	424	225	280	413	160	120	400	315	254	M14	M12	381	140	-	65	38	125	100	1030	530	640	0,349	213
NKM-G 100-250/270/15/4	140	80	254	542	424	225	280	413	160	120	400	315	254	M14	M12	381	140	-	65	38	125	100	1030	530	640	0,485	237